

450AJ HC3

ARTICULATING HI-CAPACITY BOOM LIFT



Performance

Platform Height	45 ft	13.72 m
Horizontal Outreach	25 ft	7.62 m
Up and Over Height	24 ft	7.3 m
Swing	355 Degrees Non-Continuous	
Platform Capacity		
Restricted	750/1000 lb	340/454 kg
Unrestricted	660 lb	300 kg
Platform Size	30 x 72 in.	0.76 x 1.83 m
Platform Rotator	180 Degrees Hydraulic	
Jib	4 ft 1 in.	1.24 m
Range of Articulation	145 Degrees (+76, -69)	
Weight	16,550 lb	7,507 kg
Max Ground Bearing Pressure	76 psi	5.34 kg/cm ²
Drive Speed	4.25 mph	6.84 km/hr
Gradeability		
4WD	45%	
Tilt Cut Out	5 Degrees	
Axle Oscillation	4 in.	10 cm
Turning Radius		
Inside	6 ft 9 in.	2.06 m
Outside	15 ft 8 in.	4.78 m

3 Capacity Zones - Each rated for 3 occupants + tools/materials

HC3



Standard Specifications

Power Source

Diesel Engine		
Deutz D2.9 L4 Tier 4 Final	49 hp	36.4 kW
Fuel Tank Capacity	16 gal.	60.6 L

Hydraulic System

System Capacity	17.3 gal.	65.5 L
Tank Capacity	15 gal.	56.8 L
Auxiliary Power	12V-DC	

Tires

Standard	33 x 12 D610 Foam Filled
Optional	Non Marking Foam Filled Tires

Standard Features

- 4 ft 1 in. (1.24 m) Articulating Jib
- Platform 30 x 72 in. (0.76 x 1.83 m) Side Entry
- 180 Degree Hydraulic Platform Rotator
- Platform Console Machine Status Light Panel¹
- 110V-AC Receptacle in the Platform
- 5 Degree Tilt Alarm/Indicator Light
- Swing Out Engine Module
- Improved Multi-Function Controls
- Gull-Wing Turntable Hoods
- 12V-DC Auxiliary Power
- Hourmeter
- Interactive Display at Ground Controls
- Proportional Controls
- Control ADE[®] System
- Lifting/Tie Down Lugs
- Horn
- Four-Wheel Hydrostatic Drive
- Oscillating Axle
- Cast Aluminum Control Box
- Motion Alarm
- Reduced Time to Full Height
- Load Sensing System
- SkyGuard SkyLine™

Accessories & Options

- 30 x 60 in. (0.76 x 1.25 m) Platform
- Inward Self-Closing Swing
- 36 x 72 in. (0.91 x 1.83 m) Platform
- Fall Arrest Platform 30 x 60 in. (76 x 1.53 m)
- 1/2 in. Air Line to Platform
- SkySense™
- Soft Touch System
- AC Generator
- Flashing Amber Beacon
- Cold Weather Kit²
- Hostile Environment Kit³
- Arctic Package⁴
- Light Package⁵
- Operator Tool Tray
- Accessory Packages
 - SkyPower[®] Package
 - SkyWelder[®] Package

1. Provides indicator lights at platform control console for system distress, low fuel, 5 degree tilt light, and foot switch status.
2. Includes battery blanket, hydraulic tank heater and block heater.
3. Includes boom wipers, cylinder bellows and console cover.
4. Includes arctic hydraulic hoses (drive and steer only) and main boom cable, extreme cold engine oil, fuel conditioner, engine block heater, battery blanket, glow plugs, hydraulic tank heater, and oversized footswitch.
5. Includes platform work lights, head and tail lights, amber beacon.

Note: Some options may increase lead time, and some option combinations may not be available.

Additional accessories and options available via JLG Aftermarket.

450AJ HC3

ARTICULATING HI-CAPACITY BOOM LIFT



Dimensions

All dimensions are approximate.

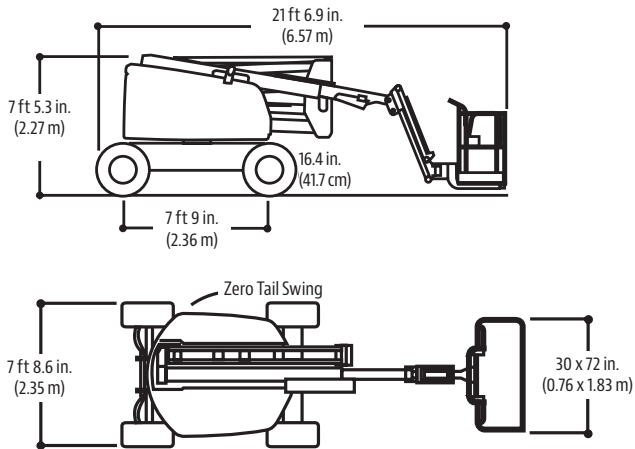

Reach Diagrams

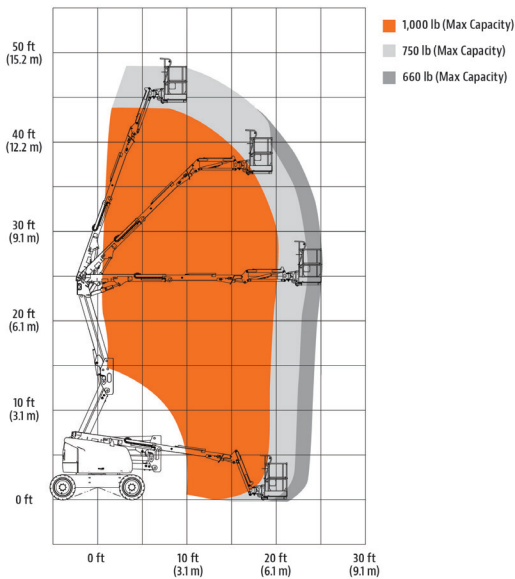

The JLG "1 & 5" Warranty

We provide coverage for one (1) full year, and cover all specified major structural components for five (5) years. Due to continuous product improvements, we reserve the right to make specification and/or equipment changes without prior notification. This machine meets or exceeds applicable ANSI and CSA requirements based on machine configuration as originally manufactured for intended applications. Please reference the serial number plate on the machine for additional information.

Part No.: 3131128
R 072121
Printed in USA



JLG Industries, Inc.
1 JLG Drive
McConnellsburg, PA 17233-9533
Telephone 717-485-5161
Toll-free in US 877-JLG-LIFT
Fax 717-485-6417
www.jlg.com

An Oshkosh Corporation Company